



120v



Intertek

S-BOX™ CHAMELEON

2-Port (1 x Socket + A+C USB 25W)



3-Port with 2 sockets + A+C USB 25W

POP-UP OUTLETS



2-Port (2 x Sockets)



S-Box® Chameleon pop-up outlets are very special.

Their patented 'instant lift' action delivers power points quickly and beautifully by the simple press of a finger, with no motor, no springs, and no gas struts to do so, and are cleverly designed to use the project material as their custom top.

It is, at last, now possible to provide countertop power that is camouflaged in its surroundings . . . until it is actually required! 😊

S-Box™ products are nothing like the plastic towers of the past. They are tough, stylish and discreet, and are built from solid steel.

S-BOX™

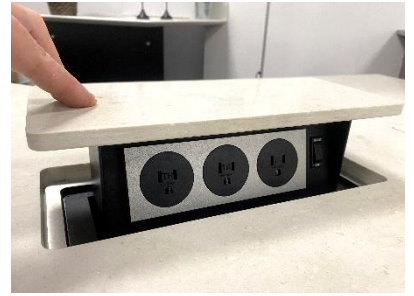

**IN NATURE, CAMOUFLAGE IS A MATTER OF SURVIVAL
. . IN DESIGN, IT'S A MATTER OF *STYLE!***



S-Box® Chameleon pop-up outlets are manufactured in a wide range of International Plug Types and are used by Designers in over 70 Countries around the world.

The S-Box™ socket box design has passed the ½ gallon Countertop Spill and Splash Tests for use in Wet Areas so it is both a stylish and safe solution for providing convenient power in any work-surface or kitchen island.



NEC 2.2 litre
(½ Gallon)
Saline Liquid Spill Test
406.5 (E)





- .. NO MOTOR
- .. NO SPRINGS
- .. NO GAS STRUTS

A "zero-energy" lift system that *adjusts* for different weight!

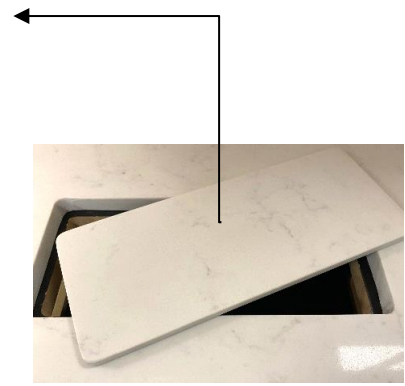
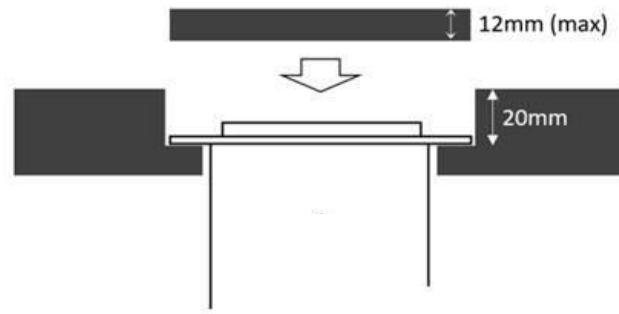

S-Box® Chameleon uses a **10-12mm piece of your work-top material** to create a camouflaged finish, and **sits on a rebate 20mm below surface**.

The patented lift system is **adjustable** to allow the unit to pop-up smoothly . . . whatever density of material is being used for the Top!

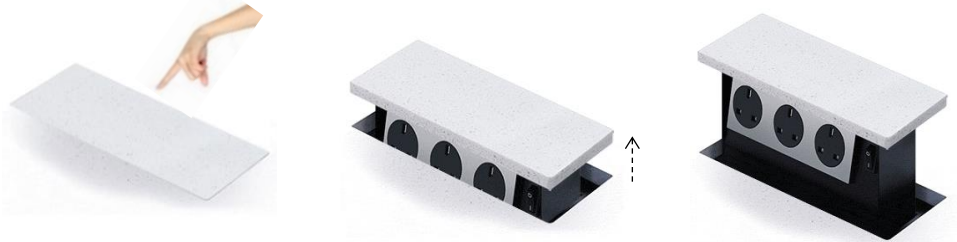

This is the engineering break-through that designers have been waiting for! A simple adaptable 'lift-system' for **any** material . . . from lightweight timber through to heavy-weight granite and quartz!

It is now possible to provide convenient countertop power without spoiling the clean lines of any design, or the beauty of a surface finish.



S-BOX™ 2012-2024

S-Box™ USB-C modules feature IDR (Intelligent Device Recognition)

S-BOX



US Patent 8899701



CANADA Patent 2700325



Intertek

“NEXT GENERATION” USB TECHNOLOGY

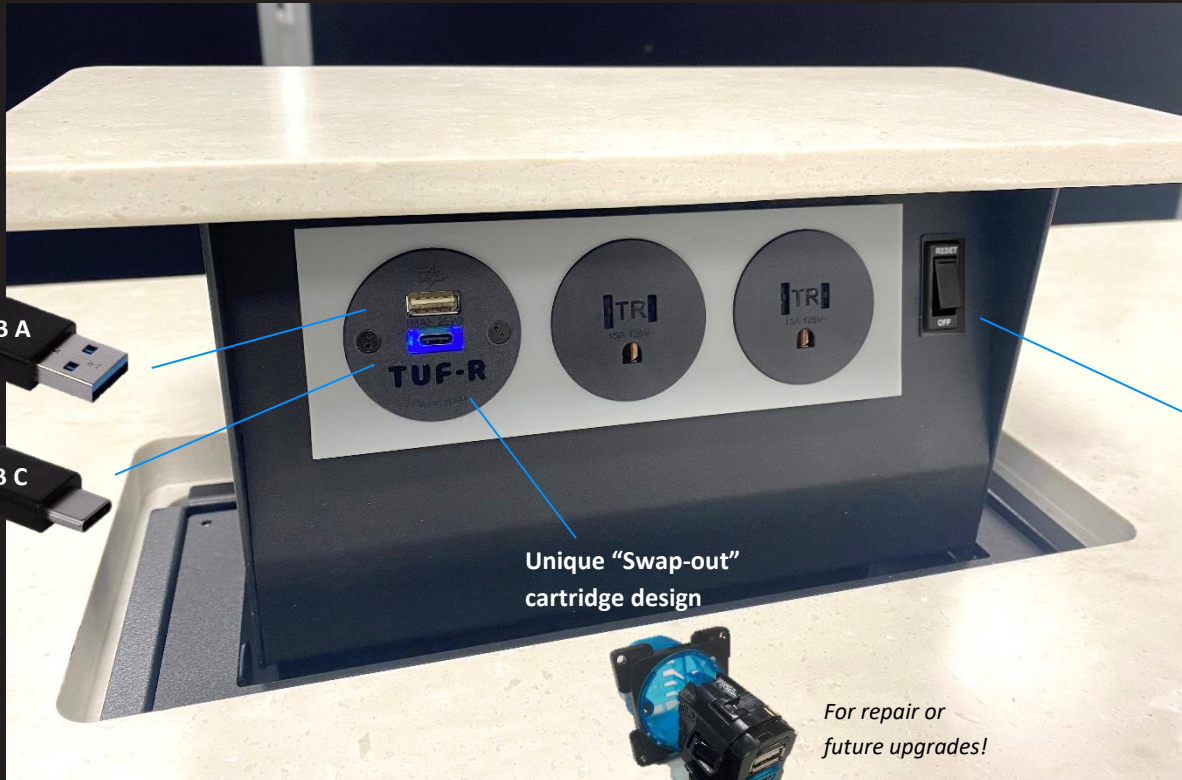

use

USB A

or

USB C

Unique “Swap-out”
cartridge design

For repair or
future upgrades!

MCB (Mini Circuit
Breaker) current
overload safety
switch set at 15A
= ‘built-in’ GFCI !

US Nema
15A outlets

25 Watts of ‘clever’ power (as Standard)

The clever TUF-R® A+C USB charger offers different supply voltages depending on the device being charged.

When a device is plugged in to either Type A or Type C port a digital ‘handshake’ takes place allowing the USB to charge the device at the optimum level.

- USB Type C
 - 5 Volts x 3 Amps = 15 Watts
 - 9 Volts x 2.22 Amps = 20 Watts
 - 15 volts x 1.65 Amps = 25 Watts
 - 20 Volts x 1.2 Amps = 24 Watts

- USB Type A
 - 5 Volts x 3 Amps = 15 Watts
 - 9 Volts x 3 Amps = 18 Watts
 - 12 volts x 1.5 Amps = 18 Watts

OR There is an **HP MODEL OPTION**
with **ULTRA-HIGH POWER** of **72 WATTS!**
For Laptop/Tablet/MacBook® & Office



Provides: 60W to Type C
12W to Type A

“Comms” options also available >



HDMI



RJ45





WORKING FROM OFFICE OR WORKING FROM HOME?

WE HAVE THE POWER AND 'COMMS' TO DELIVER WHAT YOU NEED



HDMI



RJ45



USB-TUF 25W
(MOBILE PHONES)



USB-HP- 72W
(MOBILES and LAPTOPS etc)





2-PORT MINI

Comprising 2 x US Nema 15a (Type B) outlets

Code: SB-PS-CHAM-MINI-US



2-PORT MINI USB

Comprising 1 x US Nema 15a plus A+C USB (25W)

Code: SB-PS-CHAM-MINI-US-USB25



25W USB-C for fast Mobile Phone charging



3-PORT (3 x Sockets)

Comprising 3 x US Nema 15a (Type B) outlets

Code: SB-PS-CHAM-01-US



3-PORT (2 x Sockets + USB A+C 25W)

Comprising 2 x US Nema 15a (Type B) outlets plus A+C USB (25W)

Code: SB-PS-CHAM-02-US-USB25



25W USB-C for fast Mobile Phone charging



3-PORT (2 x Sockets + USB A+C 72W)

Comprising 2 x US Nema 15a (Type B) outlets plus A+C USB (72W)

Code: SB-PS-CHAM-02-US-USB72



60W USB-C for Ultra-high-power charging (tablets, laptops etc.)

COMMS OPTIONS

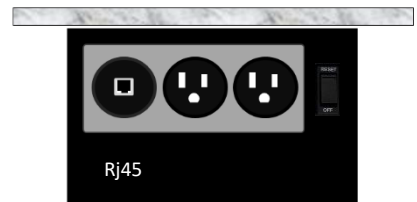

3-PORT (2 x Sockets + RJ45)

Comprising 2 x US Nema 15a (Type B) outlets plus RJ45 connection and cable tail for onward connection

Code: SB-PS-CHAM-03-US



RJ45 for Ethernet connection



3-PORT (2 x Sockets + HDMI)

Comprising 2 x US Nema 15a (Type B) outlets plus HDMI connection and cable tail for onward connection

Code: SB-PS-CHAM-04-US



HDMI for connection to Laptop & Office Presentations

RJ45 AND HDMI UNITS ALSO INCLUDE EXTENSION TAIL AND 'FEMALE' CONNECTOR.





INTERNATIONAL POP-UP OUTLETS



USED BY DESIGNERS IN 70 COUNTRIES

S-BOX™

A British Design Innovation 

National dealer in USA

Innovative Product Sales International LLC,
7815 National Service Road, Suite 610, Greensboro, NC 27409
Tel: +1 336-223-8047 Email: ken@innovativeproductsinc.com
Website: www.sbox-usa.com

National dealer CANADA

Nadon Marketing Inc,
7539 de Chaville, Laval, Quebec H7K 0A5
Tel: +1 514 245 2179 Email: info@nadonmarketing.com

S-Box™ and S-Box® are Registered Trademarks

The S-Box™ pop-up action and top-change feature are protected by International Patents in UK, EU, USA, CANADA, AU & ASIA.
The S-Box™ patents, trademark & ETL Listing are held by Cardinal Innovations Ltd, Battye Street, Bradford, W. Yorkshire, England BD4

COUNTERTOPS & ISLANDS

“Within Article 210.52(A) (1) of the 2020 NEC, it has been revised to require at least one receptacle within the first nine square feet of an island countertop and an additional receptacle for every 18 square feet more, or fraction thereof.”

AMPERAGE of OUTLET RECEPTACLES

“General-purpose outlets (such as WALL receptacles) should have a rating that is appropriate for the amperage of the circuit they serve. Generally, these household circuits will provide 15-amps or 20-amps of service, and the outlet receptacle rating should not exceed this amperage.”

There is no danger to installing 15-amp outlet receptacles on a 20-amp circuit (in fact, this is the standard practice, especially for supplemental low power accessories and countertop convenience)

“A 20-amp receptacle is generally reserved for locations where a heavy-duty appliance is typically used, such as an outlet that might power a freezer, cooker or washing machine but it is only installed on a 20-amp or larger circuit.”

What is a GFCI Receptacle?

“You can tell if a receptacle is a GFCI one or not by the way it looks.

The GFCI is integrated into an electrical outlet and it typically has a red (or possibly white) reset button on the outlet's faceplate. The outlet monitors how much energy is going into it when in use.



“If the receptacle senses any sort of an electrical overload or imbalance, it is designed to trip the circuit in a fraction of a second.

GFCI receptacles are generally used instead of a standard outlet receptacle to offer protection to single outlet location”.

S-Box™ Pop-up Countertop Sockets feature their own built-in Mini Circuit Breaker (MCB) with current overload protection pre-set to 15A.

MCB = GFCI 😊



Cord and plug-connected receptacle assemblies

are Certified (Listed) for installation into stationary furniture countertops under the product category Furniture Power Distribution Units (IYNC). Cord and plug connected assemblies are investigated for compliance with the requirements in **ANSI/UL 962A**

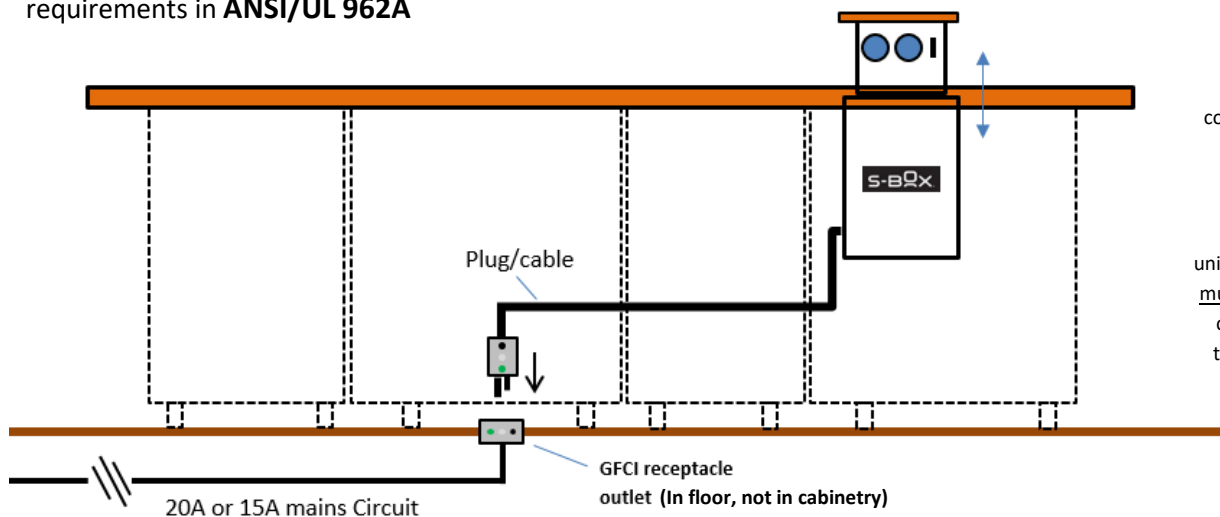

S-Box™ products are fully compliant and correctly listed for use in kitchen and bathroom countertops.

It is their extractability and unique design that means they must be corded and therefore classified as an FPDU, rather than a fixed (hard-wire-only) device under UL 498

A Kitchen Island is made of cabinetry and temporary non-permanent furniture. All kitchens are constructed from modular or hand-crafted materials (such as Timber, MDF or similar) and whilst they are of course “stationary”, they are also inherently remove-able, up-grade-able, and change-able at any time, either by the existing homeowner or any *new* homeowner who chooses to do so after purchasing an existing dwelling.

Report Number	105286428BOX-001	Issued: 29-Jun-2023	
Standard(s)	Furniture Power Distribution Units [UL 962A:2018 Ed.5+R:17Mar2022] Cord Reels and Multi-outlet Assemblies [CSA C22.2#308:2018 Ed.2]		
Applicant	Cardinal Innovations Ltd	Manufacturer 1	Cardinal Innovations Ltd
Address	Battye Street, Bradford, West Yorkshire, BD4 8AG	Address	Battye Street, Bradford, West Yorkshire, BD4 8AG
Country	England	Country	England

Description	The product covered by this report is a range of pop-up Sockets for Countertop location. For use in Stationary Furniture (such as Kitchen Islands or Kitchen cabinets). Operated/self-powered/adjustable lift mechanism by "gravity" (US Patent No. 8899701 Canada Patent No. 2700325). For Indoor use only - in kitchen countertops (as well as office and commercial locations). A corded device (to enable its removal/adjustment within its countertop location). Designed for connection to a GFCI outlet (of 20A or less) as per rules of UL 962A.
-------------	--

This authorizes the application of the Certification Mark(s) shown below to the models described in the Product(s) Covered section when made in accordance with the conditions set forth in the Certification Agreement and Listing Report. This authorization also applies to multiple listee model(s) identified on the correlation page of the Listing Report.

This document is the property of Intertek Testing Services and is not transferable. The certification mark(s) may be applied only at the location of the Party Authorized To Apply Mark.

Applicant:	Cardinal Innovations Ltd	Manufacturer:	Cardinal Innovations Ltd
Address:	Battye Street, Bradford, West Yorkshire, BD4 8AG	Address:	Battye Street, Bradford, West Yorkshire, BD4 8AG
Country:	England	Country:	England
Party Authorized To Apply Mark:	Same as Manufacturer		
Report Issuing Office:	Intertek Testing Services NA, Inc., Boxborough, MA		

Control Number: 5026088 Authorized by: 
for L. Matthew Snyder, Certification Manager



This document supersedes all previous Authorizations to Mark for the noted Report Number.

This Authorization to Mark is for the exclusive use of Intertek's Client and is provided pursuant to the Certification agreement between Intertek and its Client. Intertek's responsibility and liability are limited to the terms and conditions of the agreement. Intertek assumes no liability to any party, other than to the Client in accordance with the agreement, for any loss, expense or damage occasioned by the use of this Authorization to Mark. Only the Client is authorized to permit copying or distribution of this Authorization to Mark and then only in its entirety. Use of Intertek's Certification mark is restricted to the conditions laid out in the agreement and in this Authorization to Mark. Any further use of the Intertek name for the sale or advertisement of the tested material, product or service must first be approved in writing by Intertek. Initial Factory Assessments and Follow up Services are for the purpose of assuring appropriate usage of the Certification mark in accordance with the agreement, they are not for the purposes of production quality control and do not relieve the Client of their obligations in this respect.

Intertek Testing Services NA Inc.
545 East Algonquin Road, Arlington Heights, IL 60005
Telephone 800-345-3851 or 847-439-5667 Fax 312-283-1672

Standard(s):	Furniture Power Distribution Units [UL 962A:2018 Ed.5+R:17Mar2022]
Product:	Furniture Power Distribution Units
Models:	SB followed by -PS; followed by -SS or -CHAM; may be followed by -MINI or -01 or -02 or -03 or -04 or -05 or -06 or -07 or -08 or -09; may be followed by -TR20 or -US; may be followed by -USB25 or -USB72

THE WORKTOP - RULES 1 & 2

- 1** S-BOX® CHAMELEON MODELS are supplied **without a top**, and are designed to drop into a pre-cut hole in the Counter **on a rebate at exactly 20mm below the surface** i.e. a 'shelf' of material.
- 2** They are duly ready to receive their own matching piece of worktop (up to 12mm maximum thickness) to be used as the custom top.

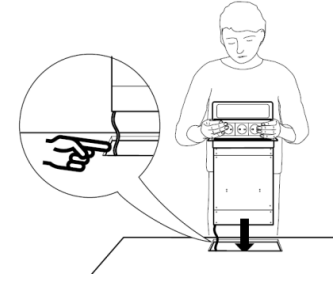

CUTTING OF STONE MATERIALS SUCH AS GRANITE & QUARTZ IS A **FACTORY PROCESS** SO PLEASE INVOLVE THE FABRICATOR OF SUCH MATERIALS IN THE DESIGN & SPECIFICATION PROCESS

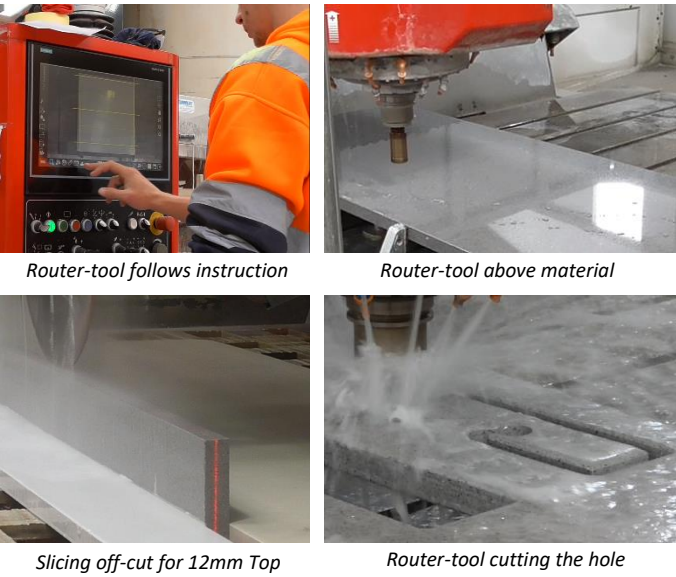
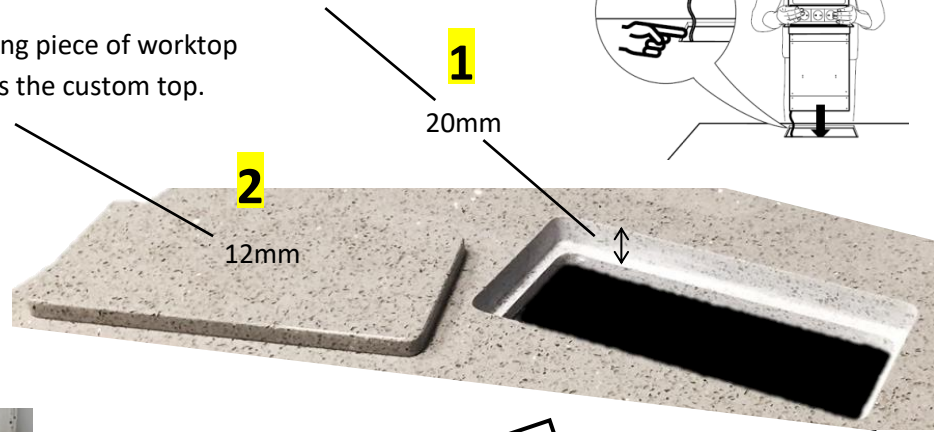

This rebate is either a **"True Rebate"** - e.g. one that is pre-cut by a router **within thick material (30mm and over)**

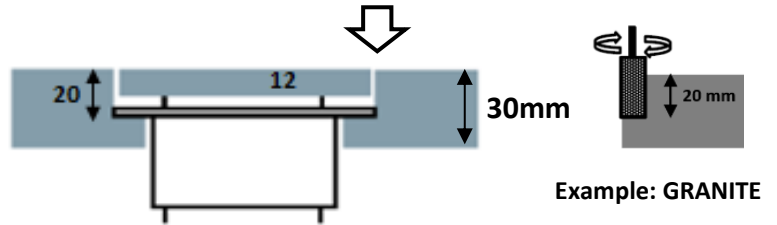

OR it is a **"False rebate"**. This is one that is *created* directly below thinner material (20mm or less) by using a **secondary material bonded underneath** to 'create' the shelf.

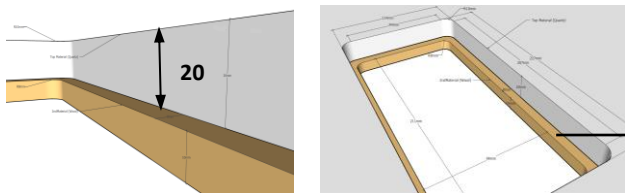
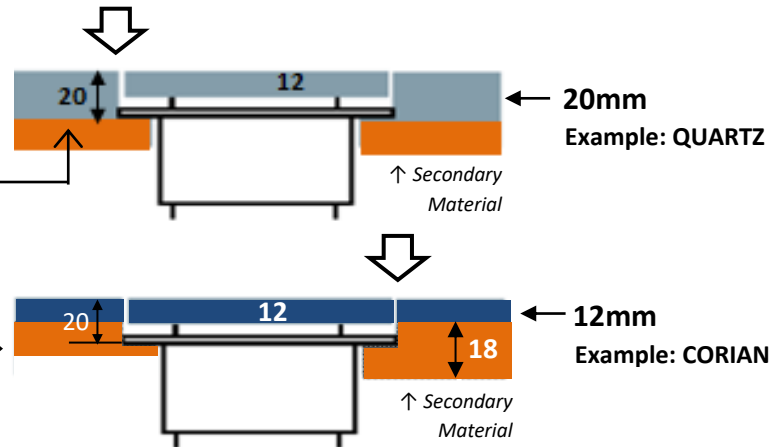

CLICK THIS LINK

FOR FULL INSTRUCTIONS + CUTTING DIMENSIONS >> <https://www.the-sbox.com/tech-data/>

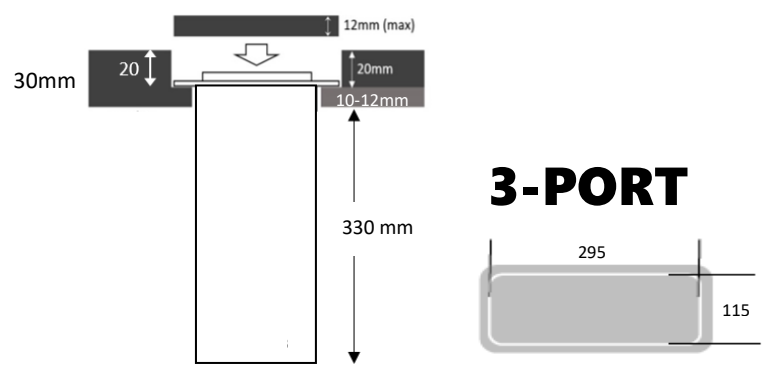
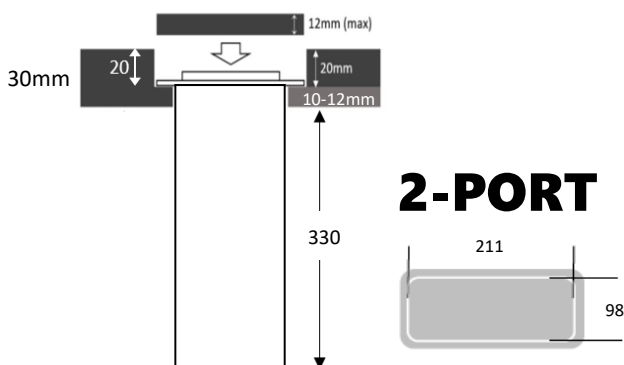



S-BOX™

CHAMELEON

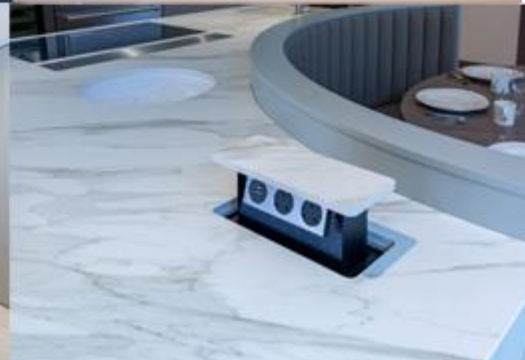



JUST IN CASE IT IS REQUIRED, THERE IS A 20A S-BOX™ MODEL WHICH ALSO DELIVERS INVISIBLE POWER TO THE COUNTERTOP. FULLY COMPLIANT AND CERTIFIED TO BOTH UL962A & CSA 22.2 STANDARDS THIS MODEL FEATURES A 20A 'DUPLEX SOCKET' DESIGN WITH SIMPLE ON/OFF SWITCH.

Note: this unit can only be connected to a 20A Circuit



The unit is installed into the Counter-top (into a 20mm rebate) as per the "TWO RULES" above and is ready to receive its 12mm max Custom Top.

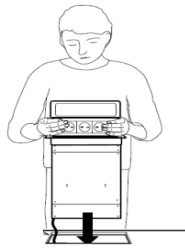

This unit has also passed the 64oz Splash test for use in Wet Areas under NEC Regulation **NEC 406.5 (E)**

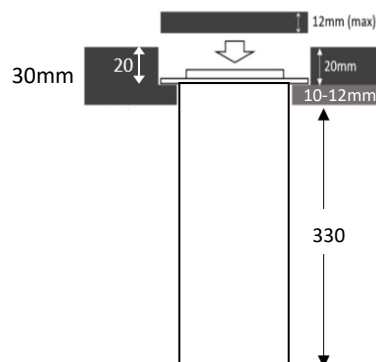

Dimensions are identical to the S-BOX™ 15A 2-PORT models

2-SOCKET DUPLEX 20A

